



Pole Platform User Guide

ELECTRICAL+INDUSTRIAL | TOOLS+TECHNOLOGIES

TMACTM
THEW &
McCANN
GROUP

ACTIVE INNOVATION



THIS PAGE HAS BEEN LEFT INTENTIONALLY BLANK

CONTENTS

CONTENTS	3
BEFORE YOU START	4
GENERAL PRECAUTIONS	4
QUALIFIED PERSON	4
SAFETY SYMBOLS USED IN THE GUIDE	4
GENERAL INFORMATION	5
DESCRIPTION	5
PRODUCT INFORMATION	5
TM12883 - 1.2 Metre Platform	5
Pole Platform with Rubber Deck	6
SAFETY	6
WORKING LOAD LIMITS	6
TM12883 - 1.2 Metre Platform	6
Pole Platform with Rubber Deck	6
LIMITATIONS OF USE	7
BEFORE USE	7
OPERATION	7
WEIGHT OF PLATFORMS	7
CARRYING AND LIFTING THE UPP-1.2 INTO POSITION	7
ATTACHING THE PLATFORM TO THE POLE	9
TM12883 (1.2m) Platform	9
Pole Platform with Rubber Deck	11
STORAGE	11
ROUTINE MAINTENANCE & INSPECTIONS	12
GENERAL	12
All Platforms	12
TM12883 (1.2m) Platform	12
Pole Platform with Rubber Deck	12
REPLACING THE POLY PADS	13
1.2m Platform Pad Replacement	13
REPLACING THE POLE SPIKES	14
Pole Spike Types	14
REPAIR	15
DEFECTS / WARRANTY	15
DEFECTS	15
WARRANTY	15

BEFORE YOU START

GENERAL PRECAUTIONS



Read and understand this guide before using the Universal Pole Platform.

This guide must be kept for future reference with the product supplied.

The TMAC Pole Platform is to be used only by qualified personnel and must be used in conjunction with the user's own working and safety procedures, without compromising the integrity of the TMAC product supplied.

Follow all safety instructions contained within this guide.

QUALIFIED PERSON

A qualified person is one who is familiar with the installation, construction, operation or maintenance of the equipment and the hazards involved. In addition this person is competent, trained and authorized to undertake the work involved in accordance with established safety and working procedures.

SAFETY SYMBOLS USED IN THE GUIDE



Mandatory Action - This symbol indicates the action must be taken to avoid a hazard. Any information that follows this symbol must be obeyed to avoid possible harm.



Hazard Identification - This is a general warning sign. It is used to alert the user to potential hazards. Any information that follows this symbol must be obeyed to avoid possible harm.



Prohibition - This symbol indicates an action that must not be taken or must be stopped. Any information that follows this symbol must be obeyed to avoid possible harm.

GENERAL INFORMATION

DESCRIPTION

The TMAC Pole Platform is designed to support a person while working on overhead conductors or equipment. It is manufactured with a lightweight aluminium frame and non-conductive deck. It may be used on round wood, steel, or concrete poles.

PRODUCT INFORMATION

TM12883 - 1.2 Metre Platform

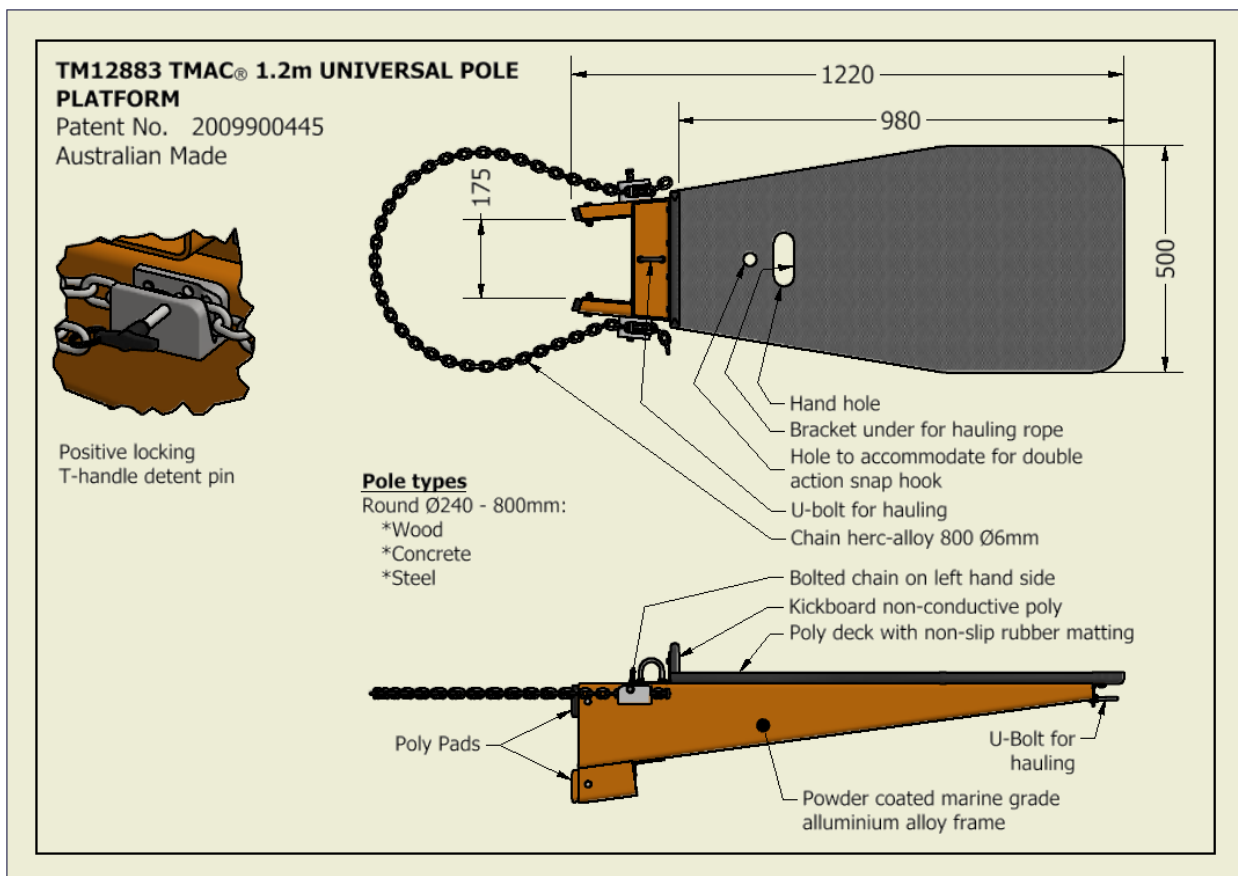

Pole Platform with Rubber Deck

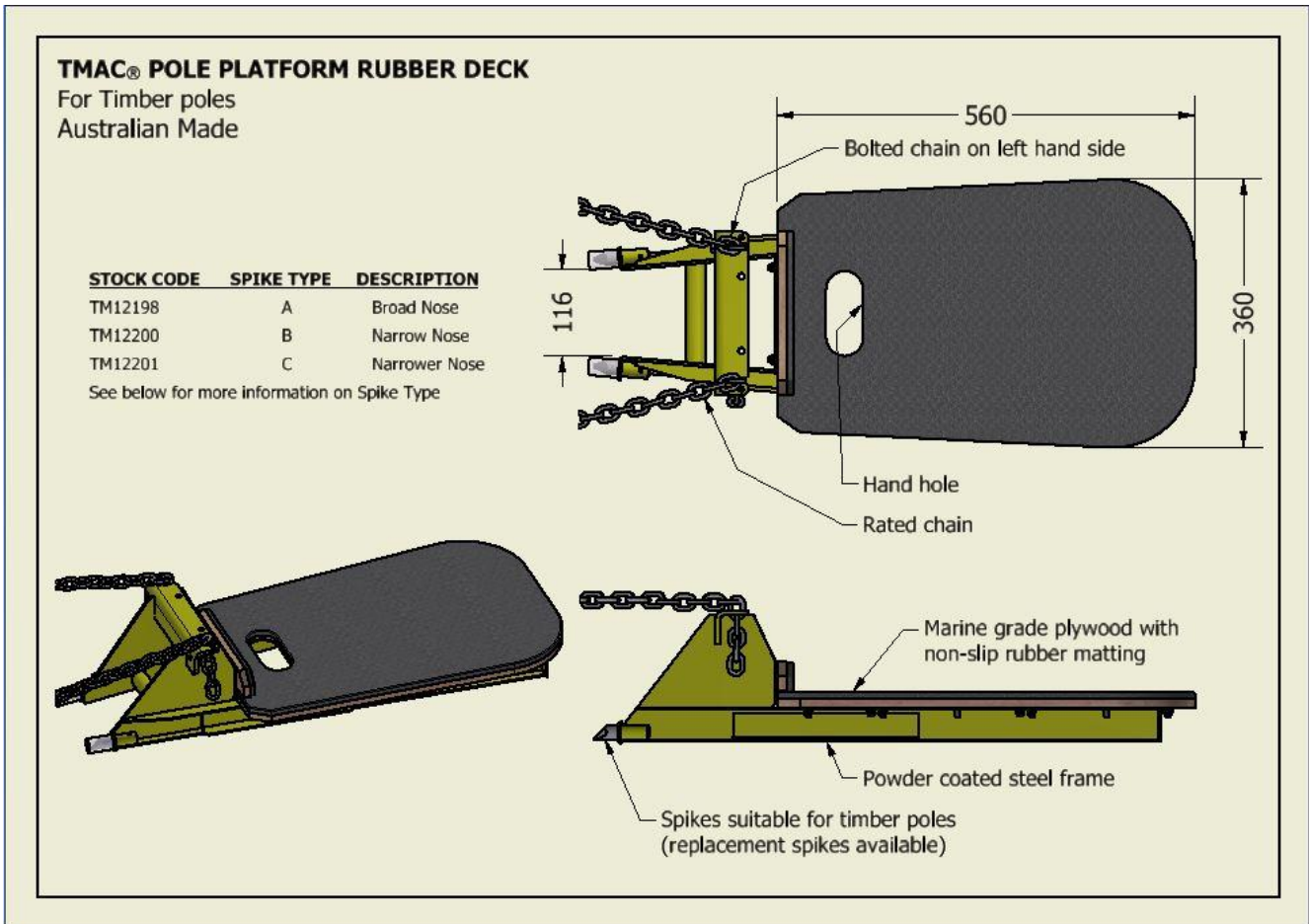

SAFETY

WORKING LOAD LIMITS

TM12883 - 1.2 Metre Platform

- Working Load Limit (WLL) – 300kg
- Pole Diameter – 240mm to 800mm
- Pole Type – Wood, Concrete or Steel.

Pole Platform with Rubber Deck

- Working Load Limit (WLL) – 150kg
- Pole Diameter – 200mm to 400mm
- Pole Type – Wood **ONLY**.

LIMITATIONS OF USE

The pole platform is only to be used within its WLL and the limits of the pole diameter. A check of the Poly Pads is imperative as when new there will be 14mm of the pad exposed from the frame and will wear over time. If the Poly Pads measure 9mm or less then the platform would be classed as defective until the pads have been replaced with new pads. If any defects are found upon inspection, the platform is not to be used until the defects have been rectified. Please refer to Repair section in this User Guide.

BEFORE USE

Each time a platform is used it must be examined for any visible damage or deterioration.

The NATIONAL CODE OF PRACTICE FOR THE PREVENTION OF FALLS IN GENERAL CONSTRUCTION annunciates specific requirements to be implemented in the interests of safety. It is essential that the requirements of this Code be implemented, in particular the production of a "Safe Work Method Statement" (SWMS) for each job as required.



In producing the SWMS particular attention must be drawn to the condition of both the operators' foot wear and the surface of the UPP deck. Both must be free from contaminants and/or grease, oil, clay or any other low friction contaminants.

The Pole Platform must be erected in such a manner that it is and remains level during the progress of the work.



NEVER use the Pole Platform if any component is damaged, worn or faulty.

OPERATION

WEIGHT OF PLATFORMS

- TM12883 - 1.2m Platform – 20kg
- Pole Platform with Rubber Deck – 15kg

CARRYING AND LIFTING THE POLE PLATFORMS INTO POSITION



TM12883 (1.2m) – The total weight of the Platform including the chain are between 15kg to 20 kg. Before carrying the platform, ensure the manual handling risks are assessed in accordance with work and safety procedures.

Note: The following pictures are applicable for the TM12883 1.2m model outlined in this guide. For the Pole Platform with Rubber Deck, refer to the instructions below.



Balanced Carry with Fingers pointing forward



Lifting with Front "U" bolt



Lifting with rear "U" bolt



Rope loop through handle to bracket under deck



Double action snap hook through hole in the deck

Carrying the Pole Platform with Rubber Deck and hoisting into position



Hoisting the Platform into position



Carrying the Platform

ATTACHING THE PLATFORM TO THE POLE



TM12883 - 1.2m Platform - The suitable pole diameter range is 240 to 800 mm.
Pole Platform with Rubber Deck – The suitable pole diameter range 200 – 400mm

TM12883 (1.2m) Platforms

1. On the ground, attach the chain to the right hand chain keeper and insert the T handle detent pin to hold the chain in place. The left hand chain keeper has a bolt inserted to lock the chain securely in position;
2. Attach the hauling rope to the platform and raise to the required position;
3. Remove the T handle detent pin to pass the chain around the pole and secure in the chain keeper;
4. Re-adjust as required, until the platform and chain are horizontal and all four pads are in contact with the pole. Then insert the T handle detent pin to ensure it is fully housed. Confirm that the chain is secure in the keeper prior to applying load to the platform.



adjusting the chain



1.2m Platform
all four pads in contact with pole



Detent pin locking chain in position

Pole Platform with Rubber Deck

1. On the ground, attach the chain to the right hand chain keeper. The left hand chain keeper has the chain securely bolted in position;
2. Attach the hauling rope to the platform and raise to the required position;
3. Pass the chain around the pole and secure in the chain in the keeper;
4. Re-adjust as required, until the platform and chain are horizontal and the two (2) pole spikes are in contact with the pole. Confirm the chain is secure in the keeper and the pole spikes are in firm contact with the pole.

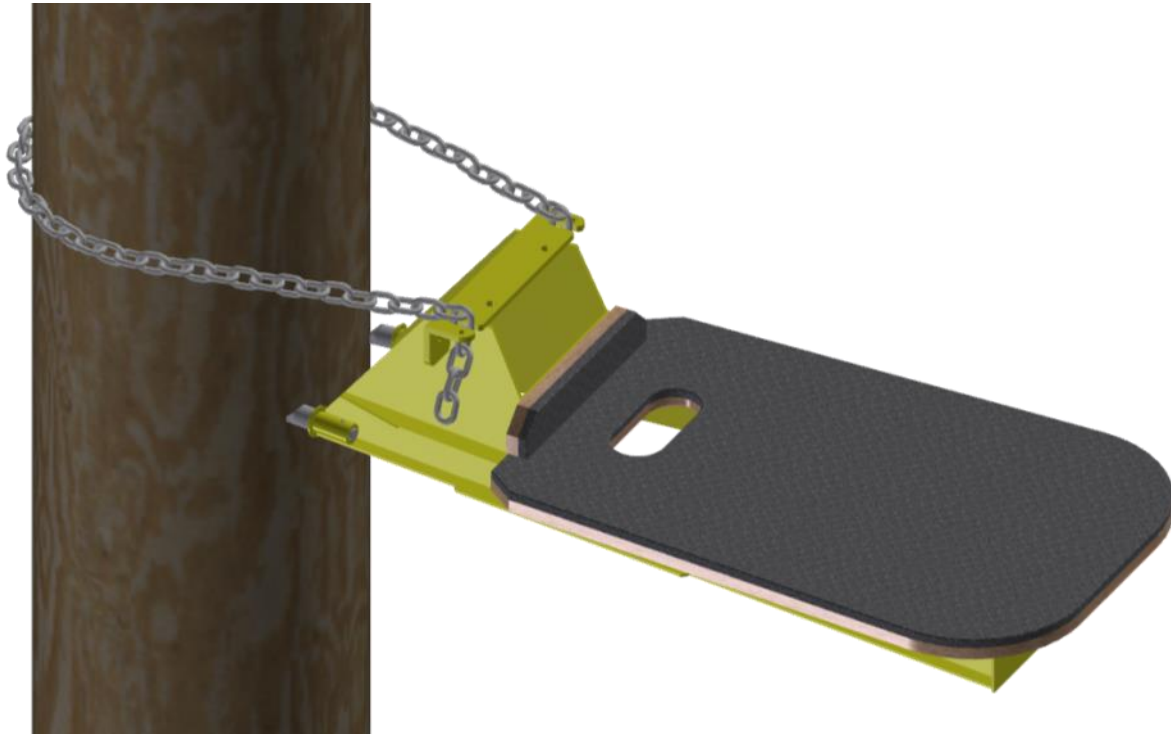

Pole Platform mounted on the pole

STORAGE

Prior to placing the unit in storage the item is to be checked for any defects and the poly pads measured to ensure they are within tolerance (see maintenance below). The chain and the locking mechanisms are to be checked and repaired if needed so the unit is ready for the next operation. When not in use, the platform should be secured to the vehicle to avoid unnecessary movement, which could impair the integrity of the platform.

ROUTINE MAINTENANCE & INSPECTIONS

GENERAL



Every 6 months and irrespective of use, the Platform must be inspected.

All Platforms

- Clean off any excessive dirt with mild soapy water, rinse and allow to dry
- Check the platform for the following defects: Cracks, deformation, permanent bending or excessive corrosion and deterioration of non-slip decking surface (Note: some surface corrosion is acceptable on the chain)
- Check all welds
- Check the chain, chain keeper, U-bolts for damage or distortion
- Check that all the nuts and bolts are tightened.

TM12883 (1.2m) Platform Only

- Check the T handle detent pin has not been damaged and the detent operates correctly
- Check the Poly Pads for wear;
 - When new: 14 mm exposed
 - Replace: minimum 9 mm exposed
- Check the detent pin is not damaged or bent and operates freely.

Pole Platform with Rubber Deck

- Check that the sharpened pole spikes that interface with the wooden pole are not damaged or broken

REPLACING THE POLY PADS

1.2m Platform Pad Replacement

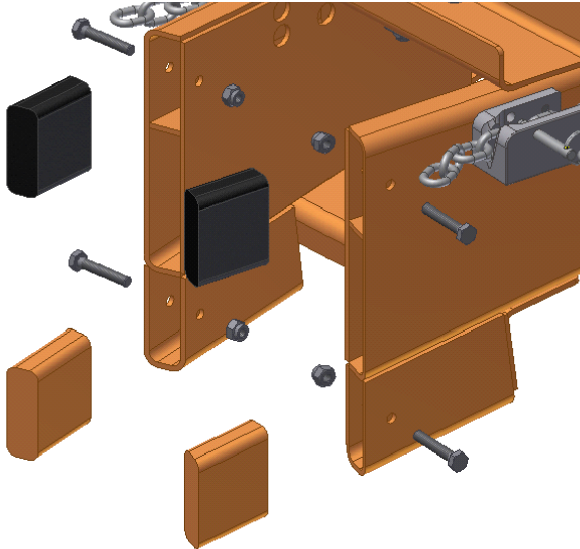

1. Remove the four nylock nuts, and then pull out the four set screws. Discard the nylock nuts and set screws; (See Note 1)
2. Remove the four pads;
3. Insert the new poly pads, with the blue pads to the top of the platform (deck side) and the orange to the bottom. Ensure the angled section on the pads are pointing inwards;
4. Next, ensure the pads are firmly seated within the frame;
5. While holding the pads in place, drill a hole through each of the four pads; (See Note 2 and image below)
6. Insert the new set screws through the frame and pads and firmly tighten the new nylock nuts.

Note 1:- 1.2m Platform has 8mm x 45mm bolts and nuts

Note 2:- 1.2m Platform drill hole is 8mm

Replacement Pads from TMAC

Part Number:- TM12892 for TM12883 – (1.2m) Platform



Drilling the holes for the replacement pads

REPLACING THE POLE SPIKES

- Knock out the spring pin that secures the pole spike in position
- Pull pole spikes directly out and clean the hole for the new spikes
- Insert the new pole spikes ensuring they go fully home and in the correct orientation (See image below)
- Drill through the pole spike and insert the new spring pin, ensure it penetrates to both sides of the pole spike holder
- Place protective piece over the sharpened pole spike to prevent inadvertent damage during transport.



Pole spike orientation

Pole Spike Types

	<p>Spike A – Broad Nose</p>	<p>TM12462</p>
	<p>Spike B – Narrow Nose</p>	<p>TM12463</p>
	<p>Spike C – Narrower Nose</p>	<p>TM12464</p>

REPAIR

The end user must not repair or modify any component associated with this device without written permission from TMAC.

If repair is required contact TMAC.

TMAC

45 Enterprise St Cleveland

QLD 4163 Australia

Tel: (+61) 07 3826 6000

<http://www.tmacgroup.com.au/>

DEFECTS / WARRANTY

DEFECTS

Goods are warranted to be free from defects. Provided they have been used strictly as recommended and subjected only to fair wear and tear, Goods (including parts within) which are found to be defective within 90 days after delivery to the Buyer will be repaired or replaced at the option of the Seller and at its expense. Repair or replacement by the Seller is the exclusive remedies of the Buyer.

WARRANTY

To the maximum extent permitted by law, the Seller makes no warranties, either express or implied, as to merchantability, fitness for purpose or otherwise with respect to the Goods other than in paragraph above and as required by statute. The Seller is not liable for any prospective profits or special, indirect or consequential damages or any general loss or damage, or for any expense resulting from use by the Buyer or others of defective Goods. The Seller's liability is limited to no more than the sale price of the Goods plus replacement delivery charges. Prior authority for the return of goods is required by the seller.

Please contact the seller by email sales@tmacgroup.com.au, phone 07 3826 6000 or fax 07 3826 6066 for claims related to defective / warranty of goods provided.

FOR THE FULL TERMS AND CONDITIONS PLEASE REFER TO TMAC "STANDARD TERMS OF TRADE"